

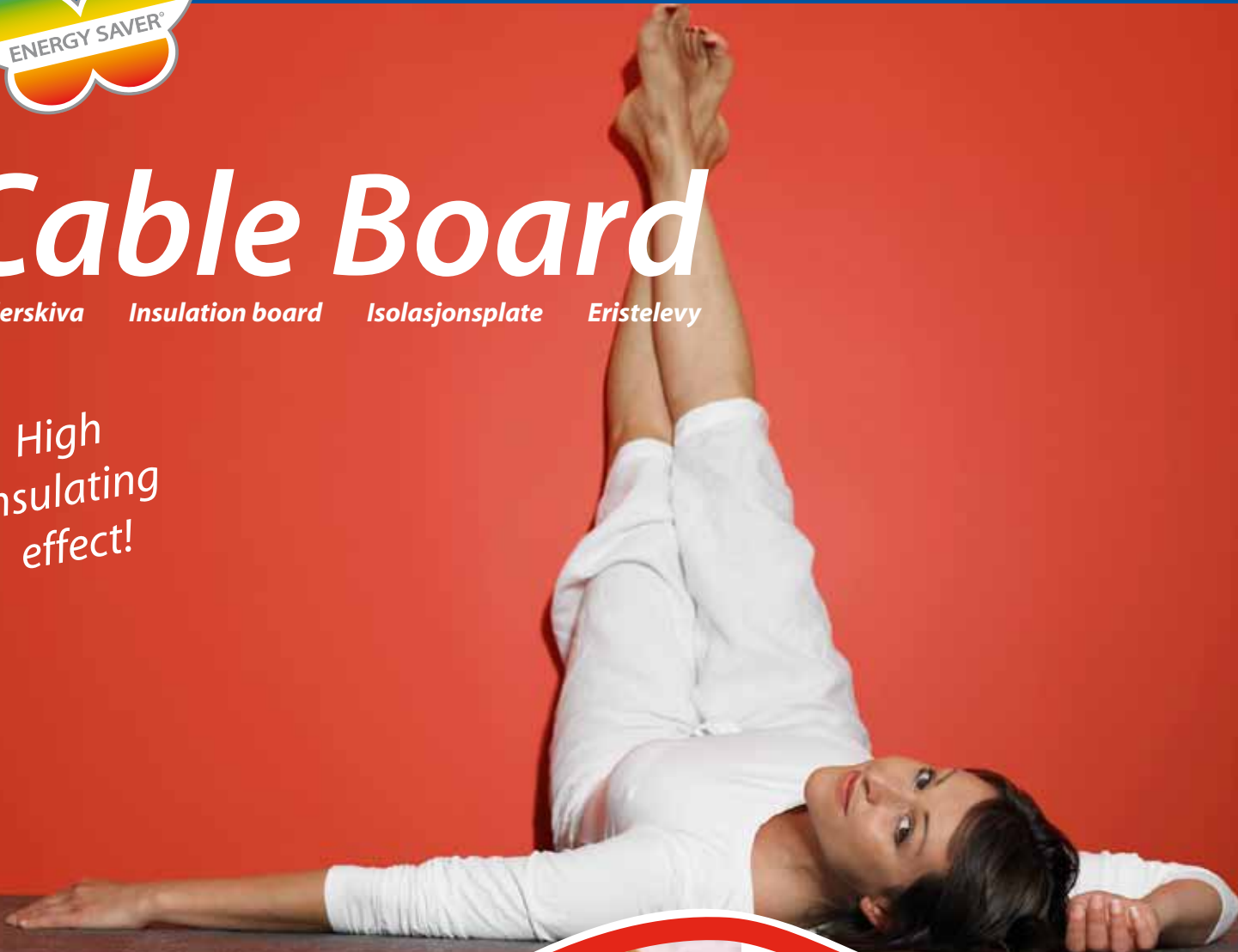

Cable Board

Isolerskiva Insulation board Isolasjonsplate Eristelevy

High
insulating
effect!



Monteringsanvisning
Installation instructions
Leggeanvisning
Asennusohje

Ebeco Cable Board

Installation instructions for Ebeco Cable Kit with Ebeco Cable Board

Begin by checking the content of the kit against the installation instructions in Cable Kit. When you install Cable Board with Cable Kit this instruction replaces the one in Cable Kit, except for the guarantee certificate.

Cable Kit with Cable board is a system for heating quarry tile and natural stone flooring laid on an existing concrete floor. The system is intended for use in normal houses without extreme weights. The spacing between the grooves is 10 cm and the power output is around 110W/m². The electrical and magnetic fields are negligible, since the cable has a built-in return cable.

- Cable Board may only be installed together with Cable Kit and E-number indicated. The system must be installed according to these instructions.
- The installation must be controlled by one of Ebeco's thermostats EB-Therm.
- The system must be connected to a 230V supply through a 30mA earth fault relay.
- **The heating cable must not be cut; only the black cold cable may be cut.**
- **The heating cable must not be crossed.**
- The lowest laying temperature is +18°. At lower temperatures the adhesion of the securing tape is reduced. Not to be fixed with hot-melt glue. The glue damages the Cable Board.
- Measure the insulation and resistance of the cable before and after laying the cable and after laying the floor, then enter the results in the test report. The guarantee is not valid without this report and the signature of an authorised electrician on the guarantee certificate.
- Only switch the heating on after the curing time prescribed by the manufacturer of the adhesive and grout. Raise the temperature gradually, otherwise there is a risk of cracking.
- The finished floor must not be covered with thick insulating rugs, beanbags or the like, as this could result in high temperatures.
- The minimum tile size is 20x20 cm if the tiles are laid directly on the adhesive. This is to prevent cracking of the joints in the flooring. If smaller tiles are used: In these cases a layer of filler must be laid between the board and the floor tiles (to spread the pressure from point loads). The thickness of the filler layer depends on the size of the tiles; for example, for glass mosaic a filler layer of at least 10 mm of fibre-reinforced flowing filler is needed, eg Uniplan.
- Because of the construction of the Cable Boards, the floor may sound slightly hollow when walked on.
- **The underfloor heating system is a high-voltage installation, which means that installation must be carried out in accordance with the relevant regulations and be supervised by a qualified electrician.**

Recommended adhesive, screed and grout

- Filling of the floor before laying the Cable Boards: Ebecos self-levelling screed Uniplan E 89 605 43, Ebecos Tile adhesive Adesilex P4 E 89 601 85, Tile adhesive Schönox TT-rapid, Tile adhesive Casco FloorFlex 3714. Putty with tile adhesive if there is a risk of moisture reaching the area.
- Priming of the floor: Ebeco Primer E 89 605 49 or equivalent.
- Installing the boards: Tile adhesive Adesilex P4, Tile adhesive Schönox TT-rapid, Tile adhesive Casco FloorFlex 3714.
- Filling the grooves and any filling over the boards: Uniplan, Adesilex P4, Schönox TT-rapid, Casco FloorFlex 3714.
- Laying the tiles: Adesilex P4, Rescon/Mapei Keraflex, Schönox TT-rapid, Casco FloorFlex 3714.
- Grouting: Rescon/Mapei Ultracolor, Schönox SU, Casco Flexo.
- When Tile adhesive Adesilex P4 and Ultracolor are used the heating may be switched on four days after grouting has been completed. For details on floor construction, filling, vapour membrane, tile laying, grouting, etc., see the relevant trade regulations or supplier's instructions.

Preparation

Start by measuring out the free area. This is the area where underfloor heating can be laid. You should therefore subtract any areas where the cable cannot be laid, such as underneath toilets bowls and other fixed furnishings. Make sure that the termination is not located in the shower. Refer to the table to see which Cable Kit you require, and check that you have the right size (For the areas in brackets, the cable is not sufficient for the two outermost grooves.) It is VERY IMPORTANT to have the correct size of Cable Kit, since it must fit the grooves and must not be cut.

Surface

The floor must be clean and flat, and any old floor covering must be removed. Any irregularities or hollows must be filled. Boards must be in full contact with the floor over their entire area, otherwise there is a risk of cracking.

Installing Ebeco Cable Board

1. Plan the installation so that the cold cable splice and the end termination are not laid in, or adjacent to, the shower area.
2. Plan how the boards should be laid to make laying the cable as easy as possible. Boards should be cut so that there is always a double slot left at the short edge of the boards that is nearest the walls (see figure 1). The best way to plan the layout is to lay the boards on the floor, number them and then remove them.
3. Before mounting the boards: cut the first part of the groove through the entire board so that any heating cables can pass over the flexible conduit, Then cut 10x10 cm in the board, with the same depth as the board(1cm) (figure 2).
4. Prime the floor. Allow the primer to dry. Apply the adhesive using an 8-10 mm serrated spreader. Press the insulation

board in place. Lay the boards with a 1 mm gap between them to allow moisture to escape. Carefully lift the board and check that the adhesion is good (figure 3).

5. Carefully seal one end of the flexible conduit. Place the flexible conduit in the slot and place the sealed end of the flexible conduit in the centre. (figure 4)

Drum holder

6. To simplify laying the cable the Cable Kit carton includes a drum holder made in plastic. Insert the drumholder through the hole on the underside of the carton. Put the drum on the drumholder and place a weight on the lid of the carton. Insert the cable through the hole in the short side of the box. When you pull the cable the drum should now turn (figure 5).

Installing the cable

Measure the insulation and resistance of the cable before laying, and enter the results in the test report.

7. Cut a slot in the board for the cold cable. Lay the cold cable in the outermost slot. Continue laying the cable in the outermost slot until you reach the nearest corner. Secure up against the wide groove with the tape. Leave the roll in place. Run the cable along the next outermost slot towards the opposite wall (fig 6).

8. Do not press the cable down into the insulation. It should "float" in the adhesive to allow heat to spread uniformly (figure 6).

9. At the opposite wall, loop the cable back along the next outermost, wide slot. Tape directly inside the wide groove. Leave the roll of tape in place (fig 7).

10. Do not let go of the cable while you stretch it between the tapes. Keep a finger on the cable all the time, otherwise it is likely to spring out of the slot (figure 8).

11. Continue in the same way with the following runs. The cable must not be laid under fixed furnishings, such as a toilet bowl, etc. Note the position of the fixing screws for the toilet bowl. If you need to cut new slots for the cable make them the same size as the existing ones. When the cable has been laid in all the slots (except the outermost) some cable will possibly be left. Lay this in the outermost slot, starting at the exterior wall (fig 9).

12. If you have to pass the "starting point" you must cut away 20 mm of the insulating board along the wall, right down to the concrete floor, since there is already cable in the outermost slot (Figure 10). The heating cable and the cold cable can be laid the same slot, but not two heating cables, as this might cause overheating.

13. Lay excess cable in the cut-out space (Figure 11). If there is any empty outer slot after the cable has crossed the cold cable in the cut-out space, let it return to the empty outer slot (Figure 12).

14. Let the cable continue in outer slots until an "occupied" outer slot is reached. If there is still surplus cable, cut away 20 mm of the insulating board down to the concrete floor and let the cable continue in the cut-out space (Figures 13A and 13B).

15. Run new lengths of tape parallel to the first lengths of tape at a distance of about 17cm which will give around 6 lengths per metre (fig 14). Never lay double lengths of tape, as this could create air pockets which can damage the cable. Press the tape down firmly. Measure the insulation and resistance of the cable again and enter the results in the test report. Record the layout of the cable with a sketch or photo and keep this near the distribution board.

16. Fill the slots. Spread the adhesive so that the cable is covered entirely and there are no air pockets (fig 15). Allow the adhesive to dry. If the cable sticks up out of the fixing, insert a nail in the board at an angle over the cable to hold it down. Remove the nail when applying the floor finish.

17. Apply new adhesive and lay the tiles. The filling and tiling can be carried out at the same time, but this is more difficult. Measure the insulation and resistance of the cable once again and enter the results in the test report.

BATHROOMS AND UTILITY ROOMS

In bathrooms and utility rooms the cable must be laid entirely in accordance with the above instructions. When inclines to floor drains are to be filled, do not lay the boards right up to the drain, not in the actual shower section. Lay the cable against the concrete floor. Lay a bed of filler on the floor. The vapour barrier should then be laid according to a type-approved

procedure. Because the filling and tiling are carried out at different stages, measure the insulation and resistance of the cable between these stages to check that the cable has not been damaged during filling.

Choose the correct size of Cable Kit

Tolerance: ± 10%

AREAL	CABLE KIT 300	CABLE KIT 200	RESISTANCE
1,4-1,9m ²	E 89 608 70	E 89 608 50	350 Ohm
1,9-2,4m ²	E 89 608 71	E 89 608 51	260 Ohm
2,3-3,0m ²	E 89 608 72	E 89 608 52	207 Ohm
3,1-3,9m ²	E 89 608 73	E 89 608 53	161 Ohm
3,7-4,6m ²	E 89 608 74	E 89 608 54	133 Ohm
4,3-5,2m ²	E 89 608 75	E 89 608 55	112 Ohm
4,9-5,9m ²	E 89 608 76	E 89 608 56	98 Ohm
5,7-7,3m ²	E 89 608 77	E 89 608 57	81 Ohm
7,3-9,2m ²	E 89 608 78	E 89 608 58	66 Ohm
8,6-10,5m ²	E 89 608 79	E 89 608 59	55 Ohm
10,7-12,7m ²	E 89 608 80	E 89 608 60	45 Ohm
12,4-14,4 (15,4*)m ²	E 89 608 81	E 89 608 61	38 Ohm
15,4-17,5 (18,5*)m ²	E 89 608 82	E 89 608 62	31 Ohm
18,5-20,7m ²	E 89 608 83	E 89 608 63	25 Ohm

* For the areas in brackets, the cable will not be used for the outer two grooves.

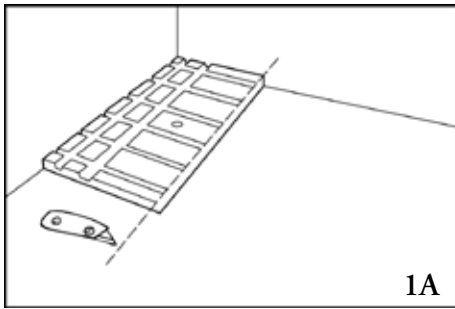

1A

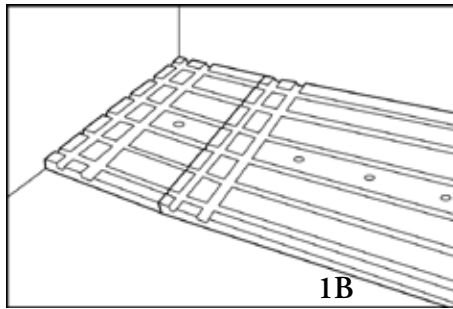

1B

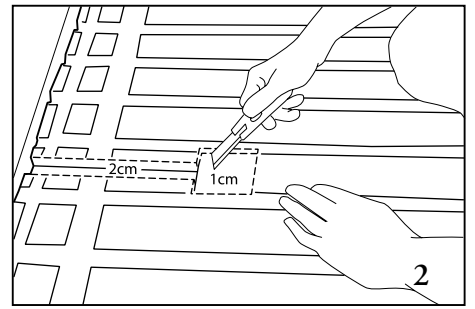

2

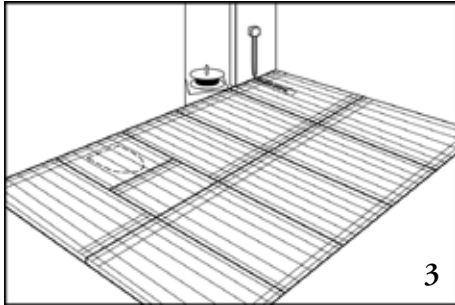

3

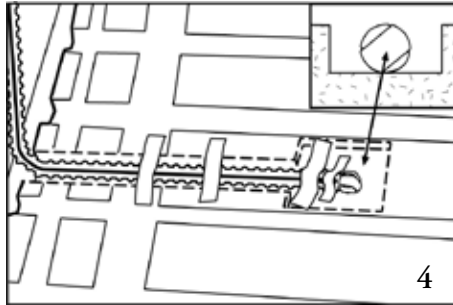

4

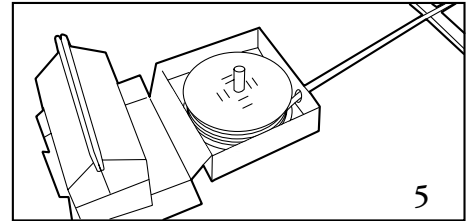
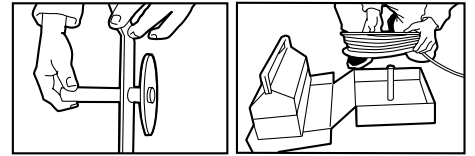

5

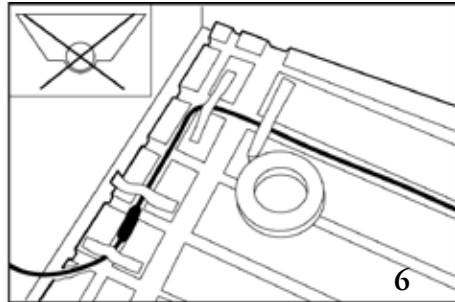

6

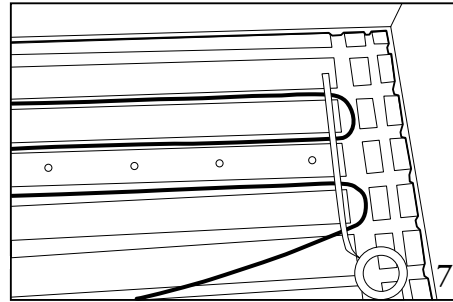

7

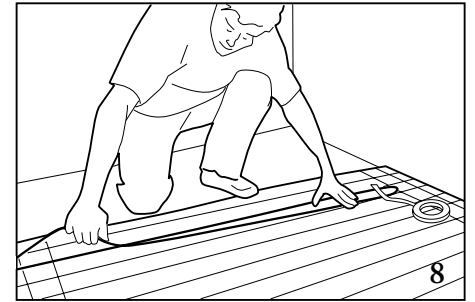

8

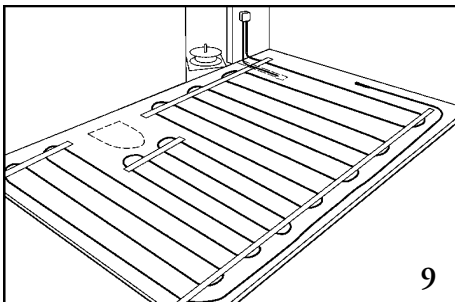

9

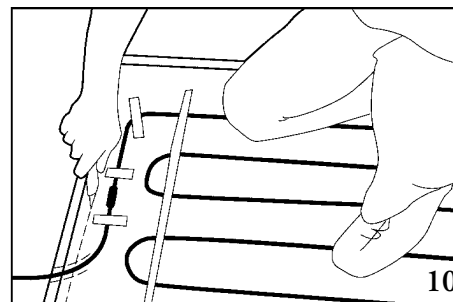

10

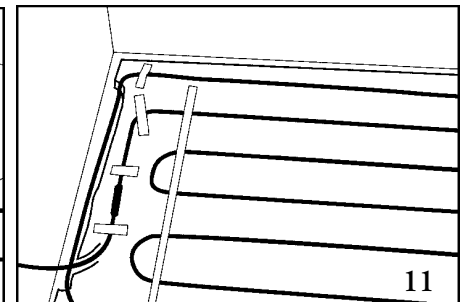

11

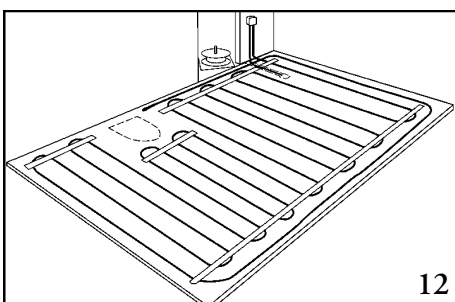

12

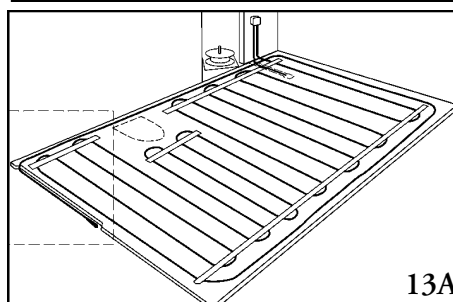

13A

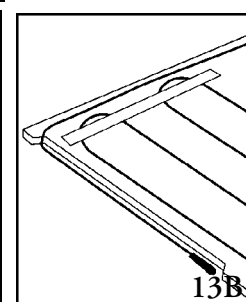

13B

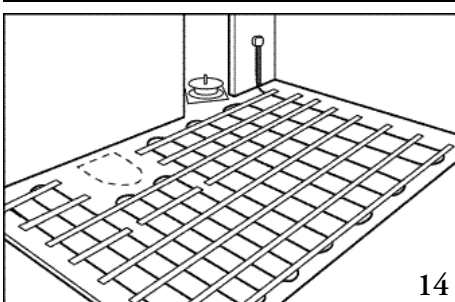

14

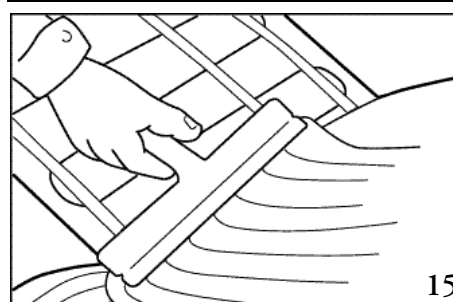

15