

# Installation instructions Ebeco Cable Kit 300

Carefully read through the entire installation instructions before starting work.

Before you start, compare the material in your Cable Kit 300 with the table below.

## Content of Ebeco Cable Kit 300

ART NO.	CABLE ART. NO.	CABLE LENGTH	THERMOSTAT	FLEXIBLE CONDUIT	GLUE STICKS	DRUM HOLDER	FIXING TAPE	SIGN	INSTALLATION INSTRUCTION
E 89 608 70	66 608 70	13.5 m	EB-Therm	1 pc	3 pcs	1 pc	2 pcs	1 pc	1 pc
E 89 608 71	66 608 71	18.5 m	EB-Therm	1 pc	4 pcs	1 pc	2 pcs	1 pc	1 pc
E 89 608 72	66 608 72	23 m	EB-Therm	1 pc	4 pcs	1 pc	2 pcs	1 pc	1 pc
E 89 608 73	66 608 73	31 m	EB-Therm	1 pc	6 pcs	1 pc	2 pcs	1 pc	1 pc
E 89 608 74	66 608 74	37 m	EB-Therm	1 pc	7 pcs	1 pc	2 pcs	1 pc	1 pc
E 89 608 75	66 608 75	43 m	EB-Therm	1 pc	8 pcs	1 pc	2 pcs	1 pc	1 pc
E 89 608 76	66 608 76	49 m	EB-Therm	1 pc	9 pcs	1 pc	2 pcs	1 pc	1 pc
E 89 608 77	66 608 77	58 m	EB-Therm	1 pc	10 pcs	1 pc	3 pcs	1 pc	1 pc
E 89 608 78	66 608 78	73 m	EB-Therm	1 pc	13 pcs	1 pc	3 pcs	1 pc	1 pc
E 89 608 79	66 608 79	86 m	EB-Therm	1 pc	15 pcs	1 pc	4 pcs	1 pc	1 pc
E 89 608 80	66 608 80	107 m	EB-Therm	1 pc	18 pcs	1 pc	5 pcs	1 pc	1 pc
E 89 608 81	66 608 81	124 m	EB-Therm	1 pc	21 pcs	1 pc	6 pcs	1 pc	1 pc
E 89 608 82	66 608 82	155 m	EB-Therm	1 pc	26 pcs	1 pc	7 pcs	1 pc	1 pc
E 89 608 83	66 608 83	187 m	EB-Therm	1 pc	32 pcs	1 pc	8 pcs	1 pc	1 pc
COMPLEMENTARY KIT FOR LARGER AREAS WITHOUT THERMOSTAT									
E 89 608 90	66 608 80	107 m		1 pc	18 pcs		5 pcs	1 pc	1 pc

## General instructions

Cable Kit 300 is a complete underfloor heating system consisting of a thin heating cable, fixing tape, glue sticks, EB-Therm thermostat and flexible conduit. A hand drum holder is also supplied, for quick, simple installation. The system is primarily intended to heat tiled and natural stone floors, but can also be installed under wood, laminate and vinyl floorcovering. The diameter of the cable is only 4 mm. The system is connected at one end and the electrical and electromagnetic fields are negligible. The system must be laid in a layer of screed, minimum thickness 5 mm, on existing flooring such as concrete, chip- or plasterboard. The system can also be laid in wooden joist floors. Begin by reading the relevant parts of the general instructions on this page, then go to the instructions for laying the system in wooden joist floors. Detailed instructions for this can be found at the end of the installation instructions.

- Check the length of the cable is correct and that the article number agrees with the table above.
- The maximum output against a combustible substrate is 120 W/m<sup>2</sup>. When installing in a wooden joist frame the maximum output is 80 W/m<sup>2</sup>.
- The maximum output on a concrete substance is 160 W/m<sup>2</sup>.
- The recommended power output in conservatories is 140-160 W/m<sup>2</sup>.
- The Cable Kit can also be installed under **wooden and laminate floors and under vinyl floorcoverings**. Here, the output should not be higher than 75 W/m<sup>2</sup> (centre spacing about 15 cm).
- For uniform heat distribution, the thickness of the self-levelling screed should be:  
Wooden floor: at least 8 mm. Laminate: at least 10 mm. Vinyl floorcovering at least 15 mm.
- The installation must be controlled by one of Ebeco's EB-Therm thermostats.
- The system must be connected to 230 V via a 30 mA earth fault relay.
- **The heating cable must not be cut or crossed. Only the cold cable may be cut.**
- Plan the layout so that the cold cable splice and the end termination do not end up in, or adjacent to, the shower area.
- In wetrooms the heating cable should be laid underneath the sealing layer.
- The lowest temperature when fixing with adhesive tape is +18° C. The adhesive properties of the tape are reduced when the temperature of the floor is lower. Screed must be applied as soon as possible after laying the cable. If there is a delay before the screed is applied, press down the tape once more before applying the screed.
- The heating cable must not be laid under fixed fittings such as kitchen units, wardrobes, internal walls, etc., since this leads to overheating.
- Measure the insulation and resistance of the cable before and after laying, and after laying the floor. Enter the values in the test report in the guarantee certificate supplied. The 10-year guarantee is not valid without the signature of an authorised electrician.
- **Wait 4 weeks before switching on the heating, then increase the level of heating gradually.**
- Where the underfloor heating system is installed over a concrete floor laid directly on the ground, the heating should not be completely switched off during the summer.
- Do not cover the finished floor with thick, insulating carpets, "bean bags" etc., since this may cause local overheating and damage the floor.
- Affix the sign supplied at the electricity distribution board ("consumer unit"). At the same location there must also be a sketch of the cable layout; see the guarantee certificate.

**The underfloor heating system is a mains voltage installation and must therefore be installed and connected in accordance with the current national regulations.**

**Resistance value Ebeco Cable Kit 300**

Tolerances ± 10 %

ART NO.	POWER	LENGTH	To be laid over a concrete substrate only		May also be laid on a combustible substrate			RESISTANCE
			AREA AT C-C APPROX. 7 CM AND 160W/M <sup>2</sup>	AREA AT C-C APPROX. 8 CM AND 140W/M <sup>2</sup>	AREA AT C-C APPROX. 9 CM AND 120W/M <sup>2</sup>	AREA AT C-C APPROX. 11 CM AND 100W/M <sup>2</sup>	AREA AT C-C APPROX. 15 CM AND 75W/M <sup>2</sup> *	
E 89 608 70	150 W	13,5 m	0.9 m <sup>2</sup>	1.1 m <sup>2</sup>	1.3 m <sup>2</sup>	1.5 m <sup>2</sup>	2.0 m <sup>2</sup>	350 ohm
E 89 608 71	200 W	18,5 m	1.3 m <sup>2</sup>	1.5 m <sup>2</sup>	1.7 m <sup>2</sup>	2.0 m <sup>2</sup>	2.7 m <sup>2</sup>	260 ohm
E 89 608 72	260 W	23 m	1.6 m <sup>2</sup>	1.8 m <sup>2</sup>	2.1 m <sup>2</sup>	2.6 m <sup>2</sup>	3.4 m <sup>2</sup>	207 ohm
E 89 608 73	330 W	31 m	2.1 m <sup>2</sup>	2.3 m <sup>2</sup>	2.7 m <sup>2</sup>	3.3 m <sup>2</sup>	4.4 m <sup>2</sup>	161 ohm
E 89 608 74	400 W	37 m	2.5 m <sup>2</sup>	2.8 m <sup>2</sup>	3.3 m <sup>2</sup>	4.0 m <sup>2</sup>	5.3 m <sup>2</sup>	133 ohm
E 89 608 75	470 W	43 m	3.0 m <sup>2</sup>	3.4 m <sup>2</sup>	3.9 m <sup>2</sup>	4.7 m <sup>2</sup>	6.3 m <sup>2</sup>	112 ohm
E 89 608 76	540 W	49 m	3.4 m <sup>2</sup>	3.9 m <sup>2</sup>	4.5 m <sup>2</sup>	5.4 m <sup>2</sup>	7.2 m <sup>2</sup>	98 ohm
E 89 608 77	650 W	58 m	4.1 m <sup>2</sup>	4.7 m <sup>2</sup>	5.4 m <sup>2</sup>	6.5 m <sup>2</sup>	8.7 m <sup>2</sup>	81 ohm
E 89 608 78	810 W	73 m	5.0 m <sup>2</sup>	5.8 m <sup>2</sup>	6.7 m <sup>2</sup>	8.1 m <sup>2</sup>	10.7 m <sup>2</sup>	66 ohm
E 89 608 79	960 W	86 m	6.0 m <sup>2</sup>	6.9 m <sup>2</sup>	8.0 m <sup>2</sup>	9.6 m <sup>2</sup>	12.8 m <sup>2</sup>	55 ohm
E 89 608 80	1180 W	107 m	7.4 m <sup>2</sup>	8.4 m <sup>2</sup>	9.8 m <sup>2</sup>	11.8 m <sup>2</sup>	15.7 m <sup>2</sup>	45 ohm
E 89 608 81	1380 W	124 m	8.6 m <sup>2</sup>	9.8 m <sup>2</sup>	11.5 m <sup>2</sup>	13.8 m <sup>2</sup>	18.3 m <sup>2</sup>	38 ohm
E 89 608 82	1710 W	155 m	10.7 m <sup>2</sup>	12.2 m <sup>2</sup>	14.2 m <sup>2</sup>	17.1 m <sup>2</sup>	22.7 m <sup>2</sup>	31 ohm
E 89 608 83	2080 W	187 m	13.0 m <sup>2</sup>	14.9 m <sup>2</sup>	17.3 m <sup>2</sup>	20.8 m <sup>2</sup>	27.7 m <sup>2</sup>	25 ohm
COMPLEMENTARY KIT FOR LARGER AREAS WITHOUT THERMOSTAT								
E 89 608 90	1180 W	107 m	7.4 m <sup>2</sup>	8.4 m <sup>2</sup>	9.8 m <sup>2</sup>	11.8 m <sup>2</sup>	15,7m <sup>2</sup>	45 ohm

\*Requires a layer of screed at least 10 mm thick for good heat distribution.

Configuration 1 is used when the heating system is laid on concrete, plaster- or chipboard

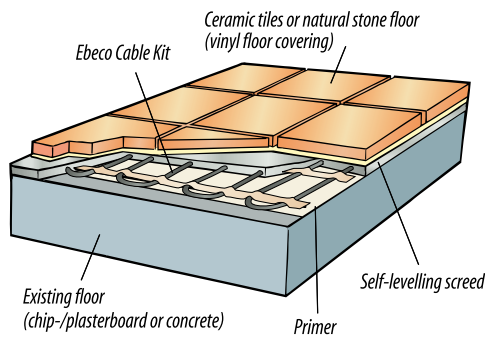

Configuration 2 is used when the heating system is laid in a wooden joist floor

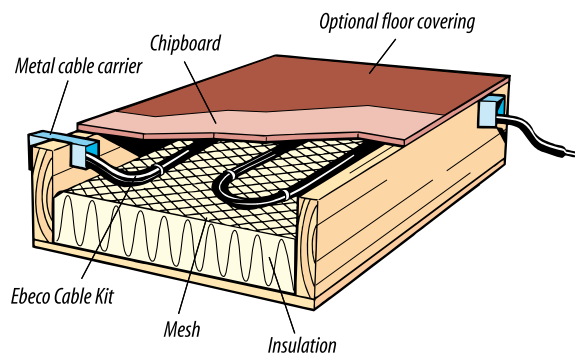

In addition to the Ebeco Cable Kit you will need:

- Self-levelling screed (Uniplan E 89 605 43)
- Primer (E 89 605 49)
- Glue gun (E 16 474 37)
- Earth fault relay, if not already installed in the building (E 21 643 06)

The following are needed when the heating system is laid in a wooden joist floor:

- Metal cable carrier (E 89 603 90)
- Plaster net, (E 89 603 92 or E 89 603 94)
- Earth fault relay, if not already installed in the building (E 21 643 06)

**Substrate**

Make sure that the floor is firm, does not sag and is free from dirt and old floorcovering material. Wood and chipboard floors over joists spaced at more than 30 cm need to be strengthened to prevent cracks from forming and tiles from coming loose. This applies even without underfloor heating.

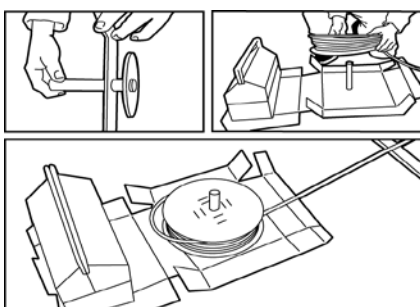

Figure 1-3

**Drumholder**

To make it easier to lay the cable, a plastic drumholder is supplied in the pack. Place the drumholder in the perforated hole under the bottom of the pack. Lift the drum on to the drum holder and place a heavy object on the lid of the pack. When you pull on the cable, the drum rotates (Figures 1-3).

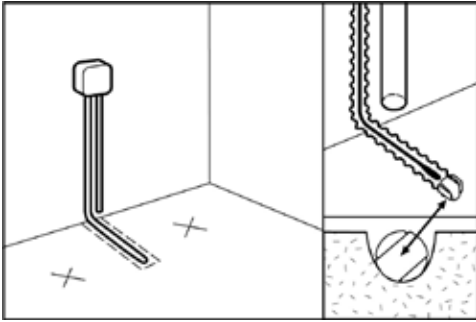

Figure 4

## Installing

Chase a groove in the floor for the flexible conduit, where the floor sensor of the thermostat will be located. Place the floor sensor between two loops of the cable (Figure 4). Position the exposed end of the flexible conduit 30-60 cm into the room, where it will not be covered by carpets or furnishing. If the bend in the flexible conduit is too sharp it will be difficult to install the sensor. Be sure to make a smooth bend. Carefully seal the end of the flexible conduit with adhesive tape (Figure 4).

The tube at the side of the flexible conduit is intended for the cold cable. In addition, the cold cable may not be bent within 10 cm from the splice. The cold cable splice must be in the floor. Make a recess in the floor so that the height of the splice is not greater than the thickness of the layer of screed.

Prime the floor surface with Ebeco Primer (E 89 605 49) and let it dry (Figure 5).

Measure the insulation and resistance of the cable and enter the readings in the test report.

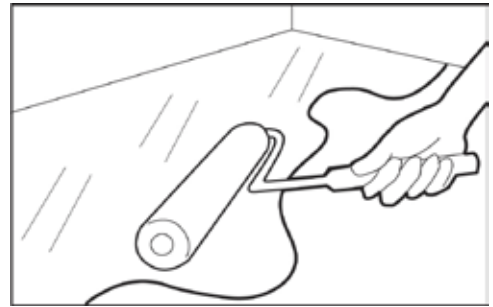
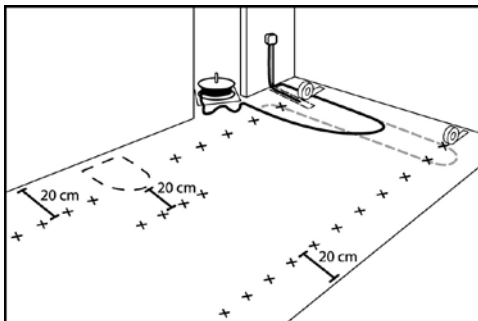

Figure 5

### TIP!

Cable Kit can be fixed with adhesive tape or hot-melt glue. Using tape halves the installation time and makes it easier to adjust the cable during the entire installation procedure. Since the pack includes both tape and hot-melt glue, instructions for both are given here. A combination of hot-melt glue and adhesive tape may be preferable. This involves fixing the cable in place with adhesive tape first and then securing the rest of the cable with glue. We recommend glue if the substrate is uneven. We recommend securing the cable with dabs of glue rather than gluing along all of the cable.



$$c/c\text{-distance} = \frac{\text{laying cable length}}{\text{cable length}}$$

Figure 6A

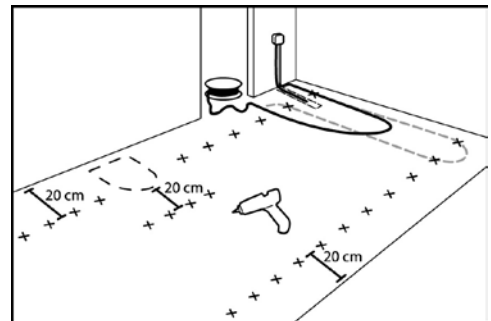

Figure 6B

Calculate the distance between centres (c/c) using the formula above. Mark the c/c measurements on the floor about 20 cm from each wall. Secure the cable with glue at the first mark (Figure 6A). If you are securing the cable with glue, apply the first spot of glue at the first mark (Figure 6B). Note: Take care when calculating and marking so that the cable fits exactly into the space.

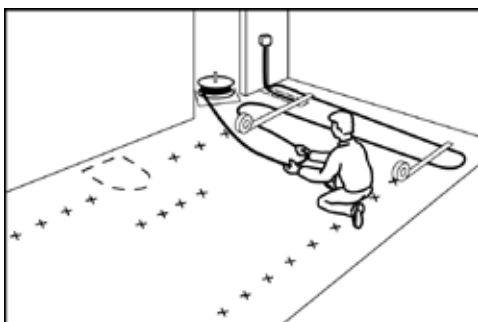

Figure 7A

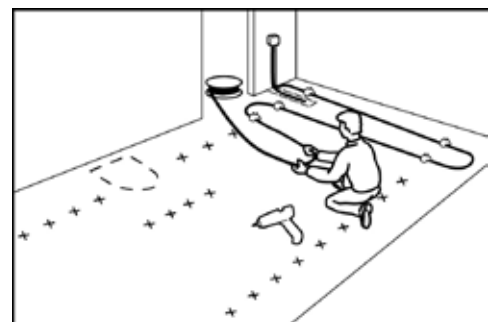

Figure 7B

Pull out the first loop of the cable and fix it with tape or glue **about 15 cm from the bend** (Figures 7A and 7B). Leave the tape reels in place during the entire installation procedure and pull out the required amount until the entire cable has been laid. Don't remove the protective paper on the upperside of the adhesive tape. The distance between the cable and the wall should be **approx. half the c/c-distance**.

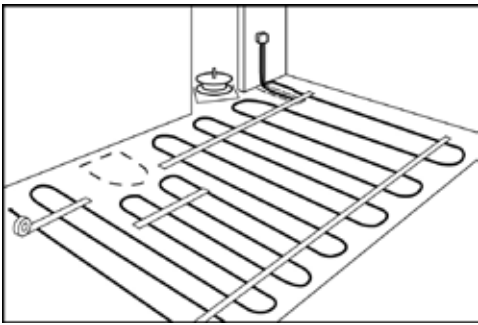

Figure 8A

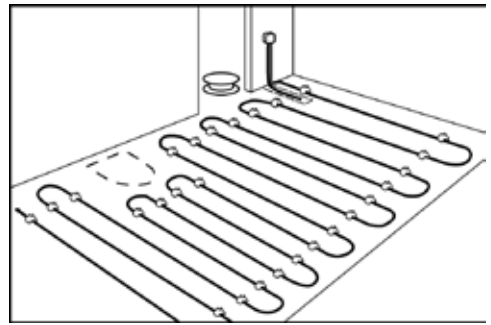

Figure 8B

Do the same with the next loop (Figure 8A and 8B). Do not lay the cable under fixed equipment, WC pans, etc. Note the position of the WC pan fixing screws.

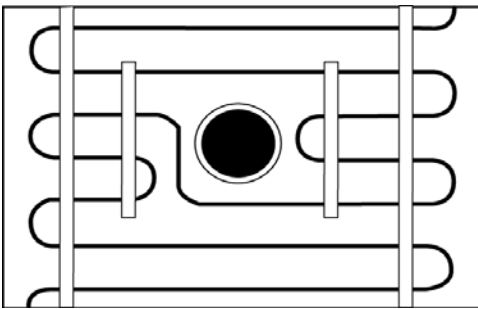

Figure 9A

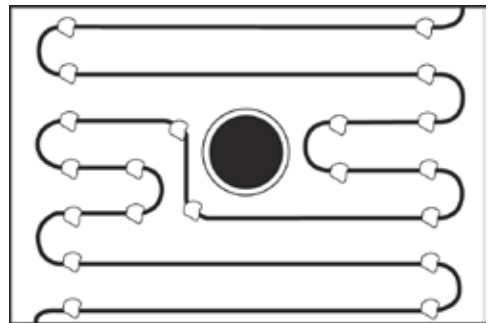

Figure 9B

At floor drains or similar obstructions, lay the cable as shown in Figure 9A and 9B. Do not lay the cable too close to the floor gully. Leave space for the floor gully grating.

When the entire cable has been laid, new strips of tape/glue spots must be applied inside and outside the first tape strips/glue spots, at a distance of 17 cm (Figures 10A+B and 11A+B).

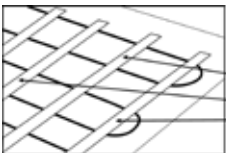

Figure 10A

The first strip of tape. Apply tape on either side of the first strip. Apply tape 2 cm from the cable bend.

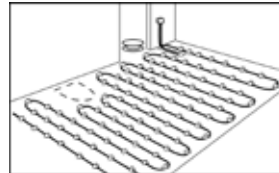

Figure 10B

The first dabs of glue.

Apply glue on either side of the first spot of glue. Apply glue at the cable bends.

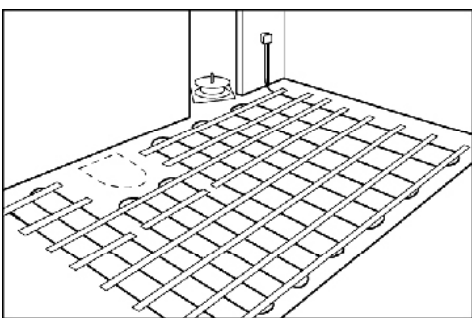

Figure 11A

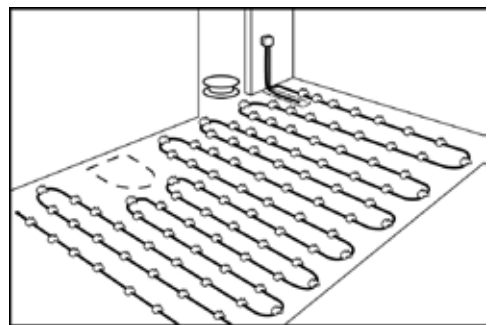

Figure 11B

If you only glued the cable you can go to the next step. To make sure that the tape sticks properly, it can be pressed down with hands or feet. This is especially important on rough and uneven surface, such as concrete. To protect the cable, wear soft-soled shoes or go barefoot. If you do not apply the screed immediately after taping the cable, you **have to** press the tape down once more just before applying the screed (Figures 12 and 13).



Figure 12

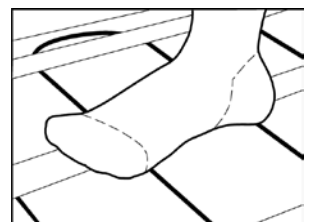

Figure 13

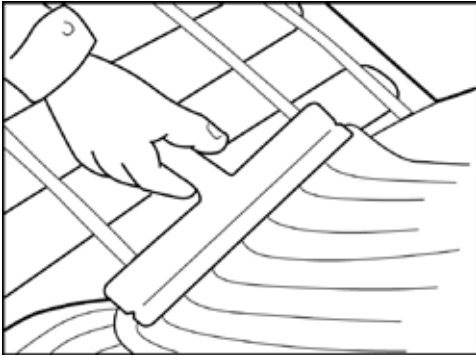

Figure 14A

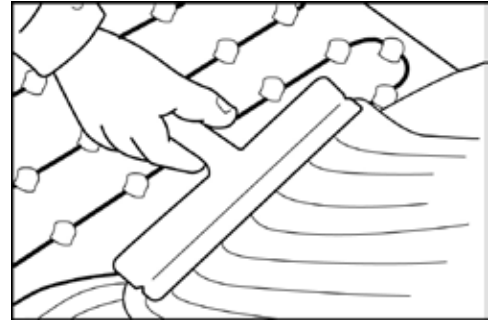

Figure 14B

Measure the insulation and resistance of the cable again and enter the readings in the test report. Record the position of the cable with a sketch or photo and keep it by the electricity distribution board. Apply self-levelling screed Uniplan (E 89 605 43) or equivalent to the floor (Figure 14A and 14B).

Measure the insulation and resistance of the cable again, to check that the cable was not damaged when the screed was applied. Lay the floor tiles in accordance with the manufacturer's instructions. Use flexible tile adhesive and grout (Figure 15).

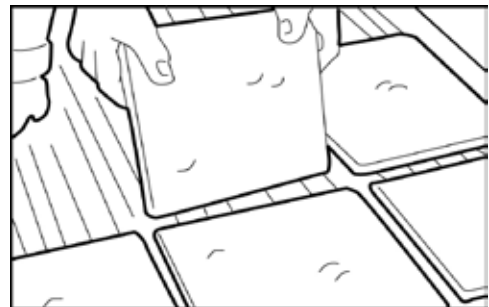

Figure 15

Measure the insulation and resistance of the cable once more and enter the readings in the test report. For floor design, filling, sealing layer, tiling, grouting, etc., see the current trade rules and the supplier's instructions.

## Laying in wooden joist floors

Lay a mesh over the insulation to form air gap of about 3 cm. Secure the mesh to the floor joists with a staple gun or similar tool. Measure the insulation and resistance of the cable before laying and enter the readings in the test report.

For simpler laying, read "Drumholder" after "General instructions".

Unreel the cable, starting at the connection box. Do not lay more than 4 loops per bay ( $c/c = 14$  cm). The cable splice must be fixed to the mesh. The fixing points must not be more than 35 cm apart. Lay the heating cable so that it crosses the joists at a wall. Cut out the batten and insert a metal cable carrier (E 89 603 90). The distance between the cable and the joists must be at least 2 cm. The cable must not touch or cross itself. Minimum distance 5 cm.

**NOTE: Maximum permitted output 80 W/m<sup>2</sup>.** With 4 loops per 60 cm bay, the output is about 75 W/m<sup>2</sup>. With 3 loops per 60 cm bay, the output is about 55 W/m<sup>2</sup>.

After the cable has been laid, its insulation and resistance must be measured again, to make sure that the cable was not damaged during laying. Enter the values in the test report. Check also that the cable is not covered with insulation or other building debris.

The room temperature is controlled with one of Ebeco's EB-Therm thermostats. The floor sensor for the thermostat is installed in a length of flexible conduit which is placed directly under the floor sheet next to a floor batten. Carefully seal the end of the flexible conduit with tape.

Lay the chipboard sheets. The floor finish is laid directly on these. Wooden floors must not be laid directly on the joists/air gap, because of the risk of uneven drying. After laying the floor, measure the insulation and resistance of the cable and enter the readings in the test report.

# Guarantee certificate

## Cable Kit, Thermoflex Kit, Foil Kit and Multiflex 20\*

Ebeco AB provides a 10 year guarantee for defective materials in Cable Kit, Thermoflex Kit, Foil Kit, Multiflex 20-cable\* and EB-Therm thermostats, henceforth called "the Products".

The guarantee only becomes valid under condition that the Products are installed by a qualified electrician according to the applicable regulations and in accordance with installation instructions issued by Ebeco. This guarantee certificate, including test record below, must be completed in its entirety and, along with the materials specification or invoice, must be signed by the electrician who carried out the installation. Furthermore, there must be photographs/sketches that show the Products in their entirety after laying but before covering.

If defects to materials should arise in the Products during the guarantee period, Ebeco AB undertakes to repair or alternatively replace the Products at no cost to the purchaser.

Ebeco AB also undertakes to restore the floor to its original condition after the repair or replacement has been completed. In order to be able to remedy the fault the purchaser must have saved or have access to 1 m<sup>2</sup> of the existing floor material. In wet rooms Ebeco AB reserves the right to lay a new cable and a new tiled floor over the top of the existing one to avoid breaking the sealing layer. For thermostats, with defects that occur after 3 years Ebeco AB supplies a new thermostat.

\*Applies only under condition that the product is installed indoors, together with Ebeco's control system.

The guarantee does not apply to installations that have been carried out by an unqualified electrician or alternatively if an unqualified electrician has carried out modifications or repairs. Nor does the guarantee apply if the defect has arisen as a result of using incorrect materials and floor construction or as a result of incorrect installation. Nor is damage covered that is a result of vandalism, fire, lightning, water damage or damage caused by negligence, abnormal usage or as a result of an accident.

In the event of a material defect arising that is covered by the guarantee Ebeco AB must be notified.

In the event of the guarantee being invoked, this guarantee certificate with accompanying invoice of installation, material specification plus completed and signed test record must be presented.

EBECO AB  
Ebbe Larsson, MD

Electrical installation carried out by:

-----  
according to enclosed materials specification.

Date: -----

Signature: -----

### Test record Cable Kit, Thermoflex Kit & Multiflex 20

Min. Insulation value 10 Mohm.

PRODUCT:	Before laying		After fixing		After floor covering	
	RESISTANCE VALUE	INSULATION VALUE	RESISTANCE VALUE	INSULATION VALUE	RESISTANCE VALUE	INSULATION VALUE
E-NO: Cable / Mat 1						

### Test Report Foil Kit

Tolerance of resistance values: -5 to +10%. Min. Insulation value 10 Mohm.

	Before laying	After fixing		After floor covering	
	Theoretical RESISTANCE-VALUE Ohm	RESISTANCE-VALUE Ohm	INSULATION-VALUE Mohm	RESISTANCE-VALUE Ohm	INSULATION-VALUE Mohm
E-NO: Installed length (m):					
E-NO: Installed length (m):					
E-NO: Installed length (m):					

230 V, 65W/m<sup>2</sup>, width: 43 cm  
 $\frac{2034,6}{\text{length (m)}} = \text{theoretical resistance value}$

Mark your drawing with the respective number

*PRODUCT:*

- Cable Kit 50
- Cable Kit 200
- Cable Kit 300
- Thermoflex Kit 100
- Thermoflex Kit 300

- Foil Kit
- Multiflex 20\*

\*in combination with:

- EB-Therm 50
- EB-Therm 100
- EB-Therm 200
- EB-Therm 300
- EB-Therm 350

*IS INSTALLED IN THE FOLLOWING ROOMS:*

- Hall
- Kitchen
- Wet room
- Living room
- Bedroom
- Conservatory
- Other.....

If the floor surface is to be replaced, the new material must be suitable for underfloor heating. Contact your flooring supplier for information. Do not position insulating material or floor fixtures on surfaces where there is underfloor heating. This reduces heat transfer into the room and produces a higher temperature in the floor.

*Length/Size*

*Power/Voltage*

\_\_\_\_\_

\_\_\_\_\_

\_\_\_\_\_

\_\_\_\_\_

\_\_\_\_\_

\_\_\_\_\_

\_\_\_\_\_

\_\_\_\_\_

A detailed sketch of the terminations and splices in the cables/mats/foil, and the exact positioning of any connection boxes must be entered above. In addition, take a photographic record of the laying process. Mark the sketch with the respective E-number from the test record. This sheet or a copy of it should be displayed beside the fuse panel. Further requirements for information for the end user are available in Swedish standard SS 436 47 53.



heating solutions

[www.ebeco.com](http://www.ebeco.com)